



FlexiShield™

Corner Guard

A-SAFE



Specifically designed to protect wall edges and door frames from day-to-day bumps and scrapes from pallet trucks.

Quick and easy to install, the stackable design allows total flexibility in its reach; enabling installation to a height to suit.

The narrow profile keeps intrusion to a minimum whilst protecting infrastructure from scuff damage from hand powered vehicles.

Tested to the
global benchmark
in barrier safety

bsi. PAS 13
Code of Practice for
Workplace Safety
Barriers

Engineered for performance

Absorption

Chevron and rectangular indents increase the surface area providing more material for energy absorption and allowing the Corner Guard to expand and contract before reforming to its original shape.

High strength

Linear low-density polyethylene delivers strong impact resistance at both ambient and sub-ambient temperatures.

Quick and easy installation

Simple assembly with modular, interlocking sections and the A-SAFE logo for clear orientation.

Highly visible

Prominent chevron design delivers a clear warning with distinctive A-SAFE yellow creating a strong visual alert.

Narrow footprint

Designed to defend against minor scuff impacts, the slimline design keeps the unit's impact on floor space to a minimum.

Adaptable

Designed to be stackable, the Corner Guard can offer protection to the full vertical height.

Colour options

Also available in black.

Technical Information

How energy (Joules) is transferred from a vehicle impact

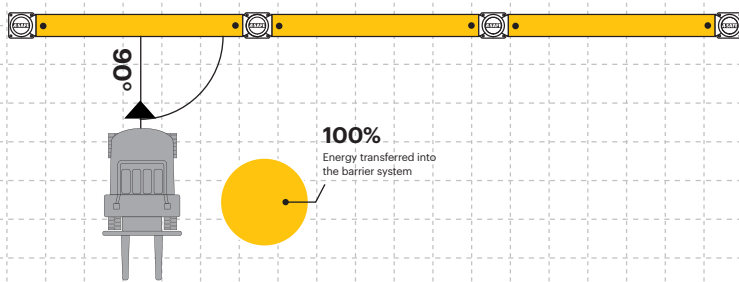

Tested Impact Energy

200 Joules

Equivalent vehicle and speed

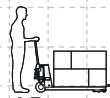

X 1 mph impact
90° Impact

Material Properties	
Temperature Range	-20°C to 50°C
Ignition Temperature	330°C to 410°C
Flash Point	341°C
Toxicity	Not Toxic
Chemical Resistance	Excellent - ISO/TR 10358
Weathering Stability (Grey Scale)	5/5*
Light Stability (Blue Wool Scale)	7/8**
Static Rating (Surface Resistivity)	Insulator (1 x 10 ¹¹ Ω/SQ)
Hygiene Seals	No

* Weathering scale 1 is very poor and 5 is excellent

** Light stability scale 1 is very poor and 8 is excellent

Dimensions (mm)

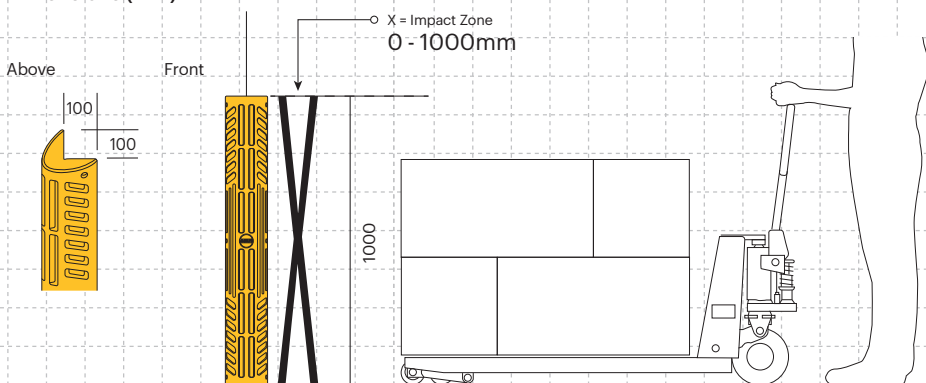

Colour Options



*Please note that the RAL and PANTONE colours listed are the closest match to standard A-SAFE colours, but may not be exact matches of the actual product colour and should be used for guidance only.